

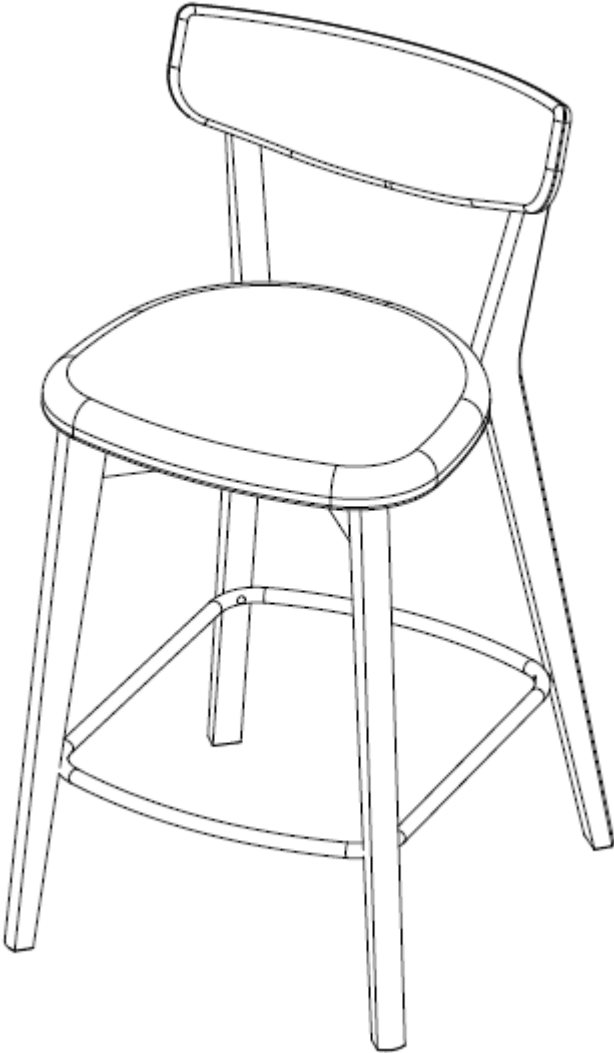

**BARKER AND
STONEHOUSE**

Jessa Counter Stool
Assembly instructions





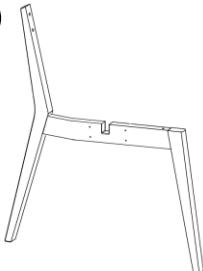
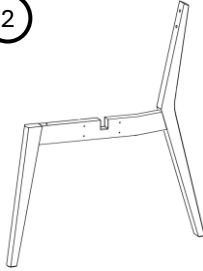
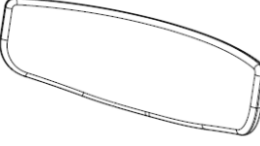

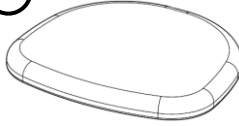
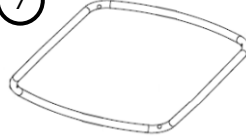
Parts checklist

Please check you have all the parts listed below with your product.

			
Frame	Frame	Back	Insert
1pc	1pc	1pc	2pc
			
Insert	Seat	Leg support	
2pc	1pc	1pc	

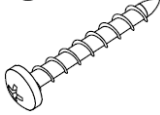
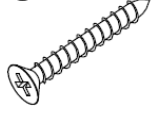
Fittings checklist

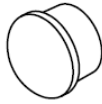
Please check you have all the fittings listed below with your product.

						
M6x20mm Bolt	40mm Screw	30mm Screw	Allen Key 4mm	Bolt Cap	Floor protector	M6x30mm Bolt
4pc	4pc	16pc	1pc	4pc	4pc	4pc

Step 1

Slot both leg frames (1) and (2) together as below.

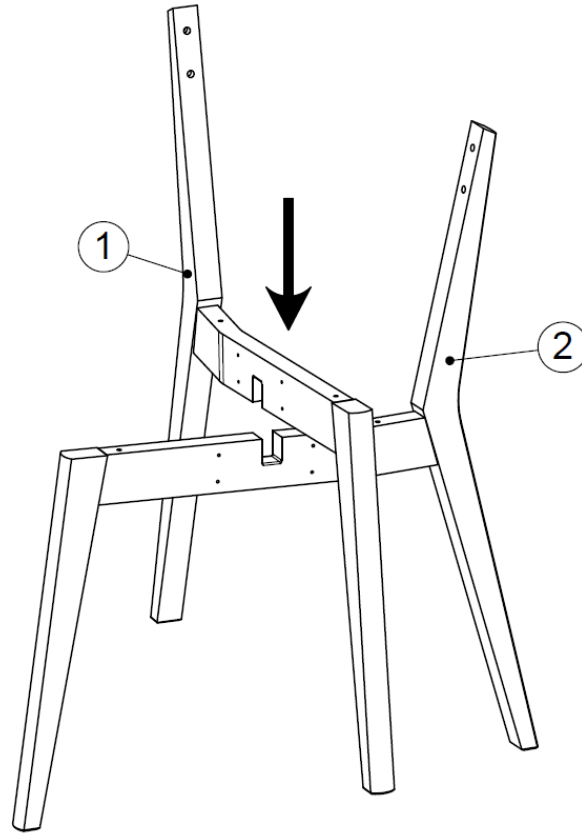

Step 2

Attach the back of the stool (3) to the top of the assembled frame and fasten with bolts (A). Don't tighten fully until the stool is sitting level (step 4).

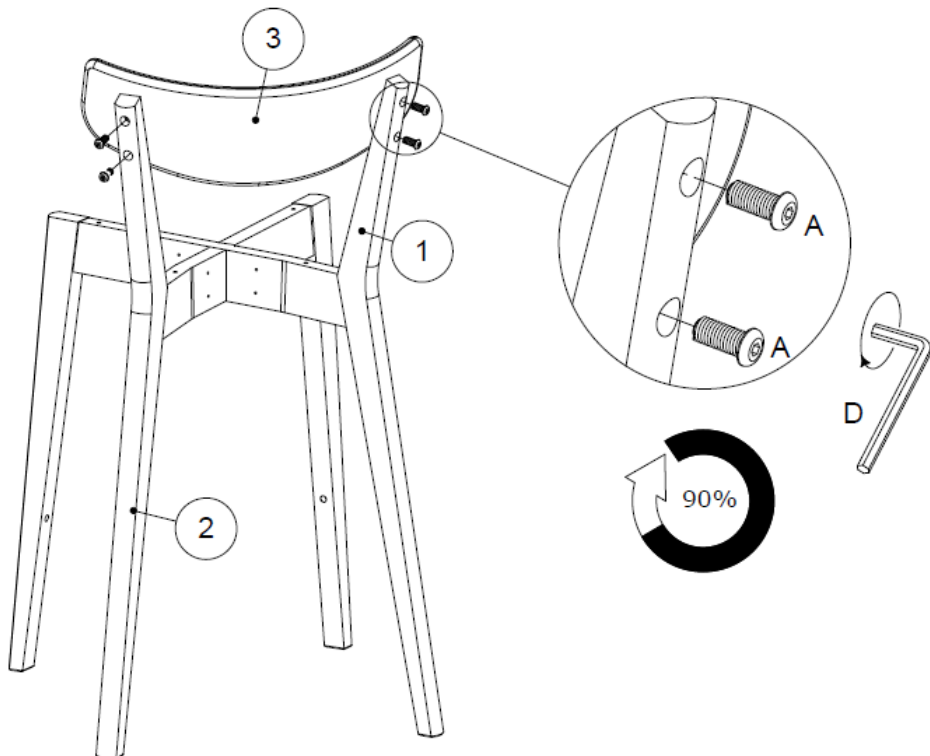

Step 3

Make sure the legs are sitting level on the floor then attach inserts (4) and (5) into adjacent corners of the leg frame and fasten with screws (C).

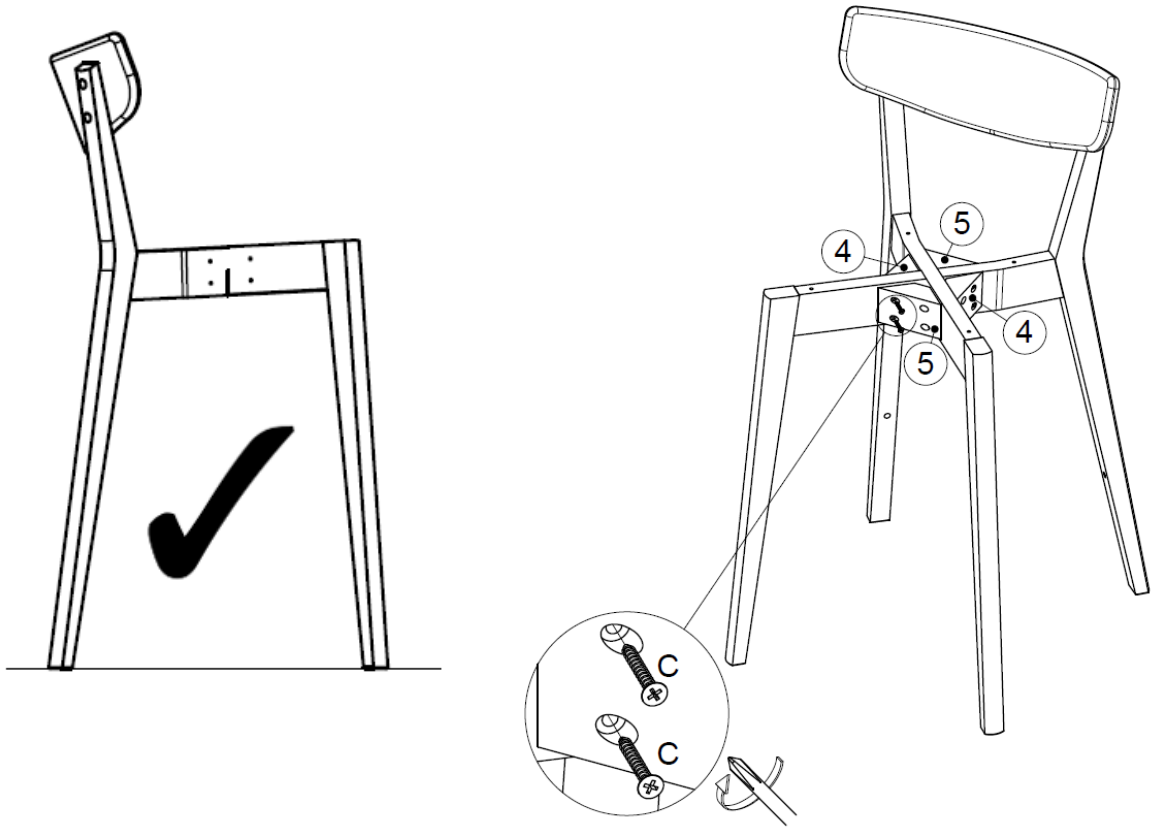

Step 4

With the stool sitting level, fully tighten the bolts on the back.

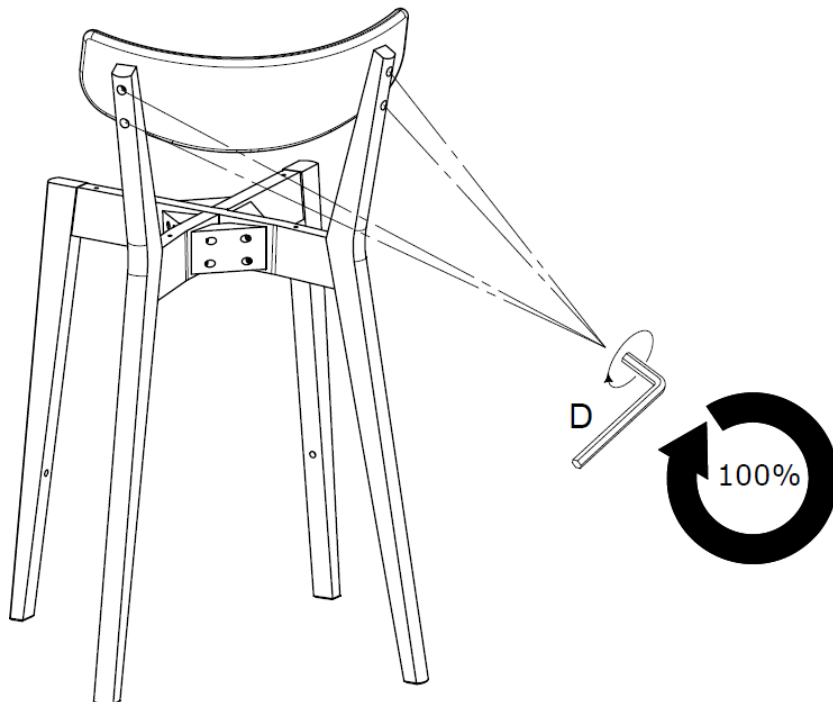

Step 5

Insert the caps (E) to cover bolts.

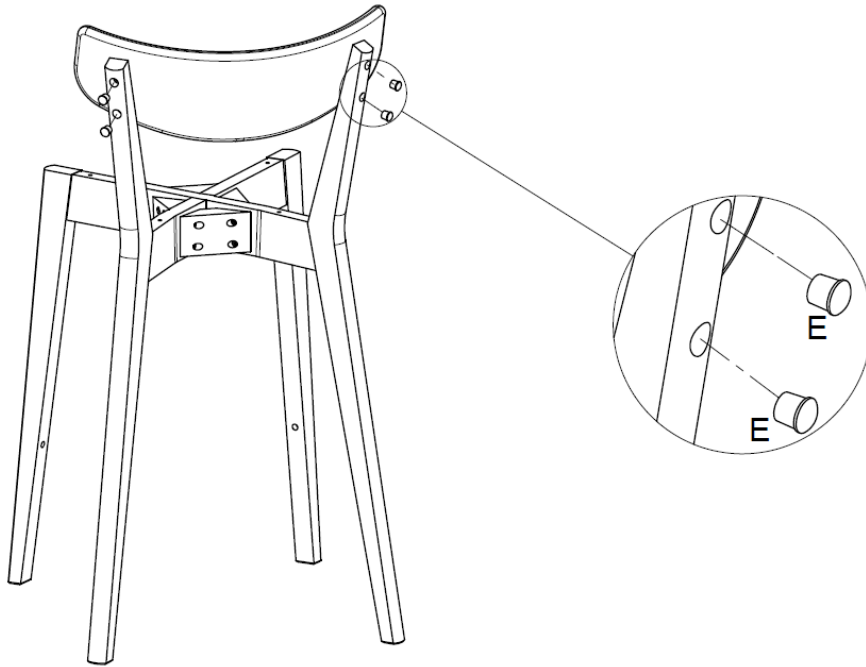

Step 6

Turn the stool upside down and position the leg support (7) in line with the holes. Attach the support with bolts (G).

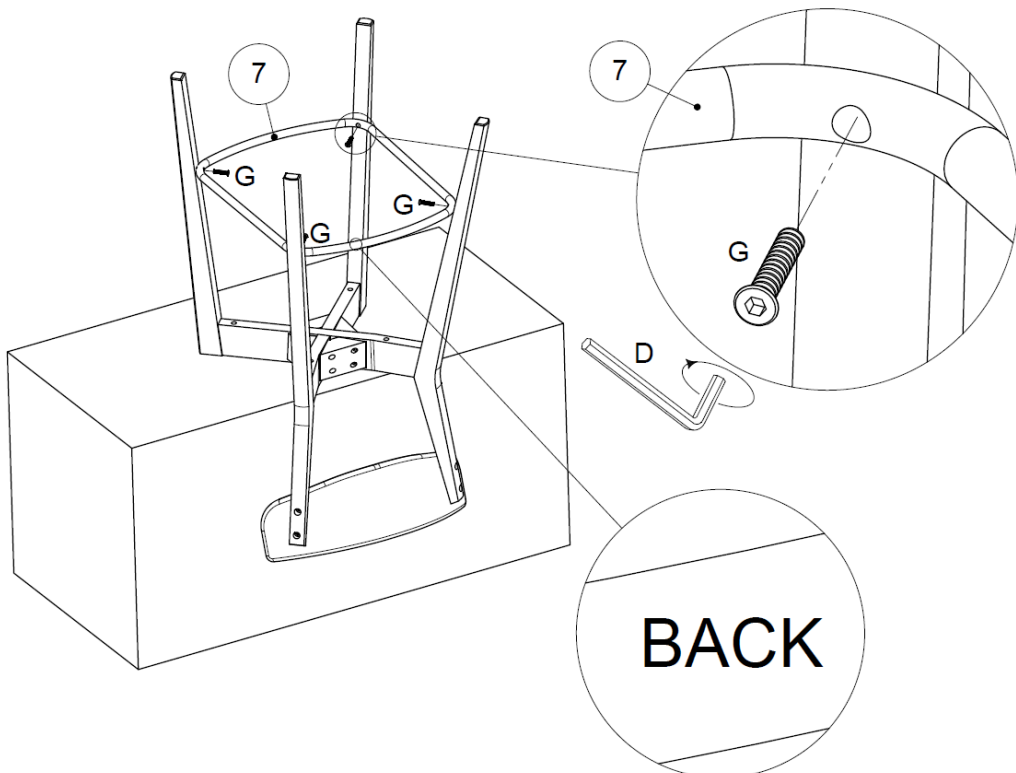

Step 7

Still upside down, sit the frame (6) on top of the seat (6) and attach with screws (B) then attach stick-on floor protectors (F) to the bottom of each leg.

